









EDELSTAHL / STAINLESS STEEL
VERBINDUNGSTECHNIK
FLUID CONNECTORS

Schweissskegel-Verschraubungen mit O-Ring Weld Nipple Couplings with O-ring





SCHWEISSKEGEL-VERSCHRAUBUNGEN MIT O-RING WELD NIPPLE COUPLINGS WITH O-RING

	Produktgruppen	Product Groups	Seite Page
	Montageanleitung	Assembly Instruction	10.2
	ESV - Schott-Verschraubungen - L- und S-Reihe - ESV - Schott-Verschraubungen - Standard - ESV - Schott-Verschraubungen - SC - ESV - Schott-Verschraubungsstutzen - OMD	ESV - Bulkhead Couplings - L- and S-Series - ESV - Bulkhead Couplings - Standard - ESV - Bulkhead Couplings - SC - ESV - Bulkhead Coupling Bodies - OMD	10.3 10.4 10.5
	ASV - Gerade Verschraubungen - L- und S-Reihe - ASV - Gerade Verschraubungen - Standard - ASV - Gerade Verschraubungen - SC - ASV - Gerade Verschraubungsstutzen - OMD	ASV - Couplings - L- and S-Series - ASV - Couplings - Standard - ASV - Couplings - SC - ASV - Coupling Bodies - OMD	10.6 10.7 10.8
	WAS - Winkel-Verschraubungen - L- und S-Reihe - WAS - Winkel-Verschraubungen - Standard - WAS - Winkel-Verschraubungen - SC - WAS - Winkel-Verschraubungsstutzen - OMD	WAS - Couplings - L- and S-Series - WAS - Couplings - Standard - WAS - Couplings - SC - WAS - Coupling Bodies - OMD	10.9 10.10 10.11
	Gerade Schweißkegel-Verschraubungen - L- und S-Reihe - Gerade Schweißkegel-Verschraubungen - Standard - Gerade Schweißkegel-Verschraubungen - SC - Gerade Schweißkegel-Verschraubungsstutzen - OMD	Welding Nipple Couplings - L- and S-Series - Welding Nipple Couplings - Standard - Welding Nipple Couplings - SC - Welding Nipple Coupling Bodies - OMD	10.12 10.13 10.14
	Schweißnippel	Welding Nipples	10.15
	Schweißnippel-Reduzierungen	Welding Nipple Reducings	10.16
	Schweißnippel-Rohrbögen - 90°	Welding Nipple Elbows - 90°	10.17

Standard = Überwurfmutter blank / Tube nuts are supplied unplated
SC = Überwurfmutter bis Größe 12-S ist ist gleitbeschichtet / Tube nuts until size 12-L are supplied chemical plated
 = Überwurfmutter ab Größe 12-S ist mit versilbertem Gewinde / Tube nuts from size 12-S are supplied with silver plated thread
OMD = Verschraubung ohne Überwurfmutter und Schneidring am Außengewinde / Couplings are supplied without nut and cutting ring at male thread

1. Rohr rechtwinkelig ablängen, entgraten und anfasen für V-Naht nach DIN 2559.
2. Überwurfmutter, wie abgebildet, über den Schweißkegel schieben.

1. Cut tube at right angles and chamfer it for V-welding seam to DIN 2559.
2. Slide nut over weld nipple arrangement as shown above.

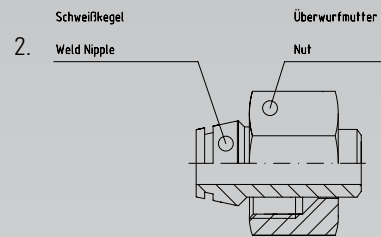
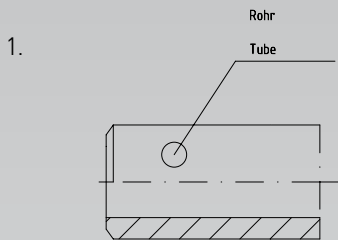

3. Schweißkegel und Rohr nach den Schweißrichtlinien verschweißen. Darauf achten, dass keine Schweißperlen ins Rohrinne gelangen. Kegel, Nut und Stutzenkonus müssen sauber sein.
4. O-Ring erst nach dem Schweißen in die Nut einlegen. Er darf sich nicht verdrehen. Schweißkegel, Konus und Innen- und Außengewinde einölen, nicht einfetten.

3. Weld nipple and tube are welded according to the general welding instructions. Please ensure that no globules of weld enter the inside of the tube. Nipple, groove and taper must be clean.
4. O-ring is only to be inserted into groove after welding. O-ring must not be twisted. Do not grease, but oil nipple, taper inside and outside of thread.

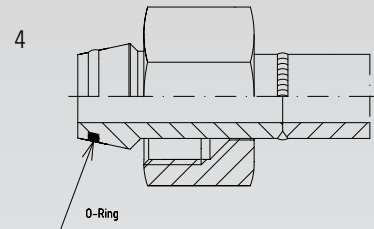
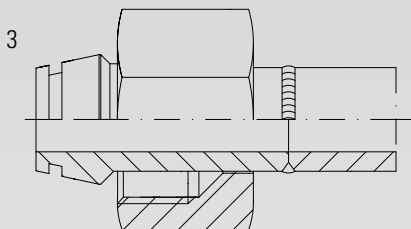

5. Überwurfmutter von Hand auf den Stutzen schrauben, dann mit dem Schlüssel ca. 1/4 - 1/3 Umdrehung anziehen. Das Rohr mit angeschweißtem Kegel muss spannungsfrei verschraubt und verlegt werden.

5. Screw the nut by hand onto the body, tighten nut with a spanner approx. 1/4 – 1/3 of a turn. Tube with welded nipple has to be installed free of tension.

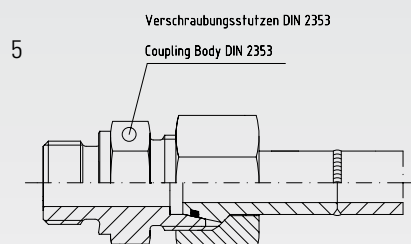



Einschweiß-Schottverschraubungen

Welding Bulkhead Connections

Reihe Series	Druck Pressure PN	Rohr A.D. Tube O.D.		Ca. Maße Approx. Dimensions			Bestellzeichen Order-Code Standard	Brutto-Preis Gross-Price Euro (€)
		D1	D2	L1	L2	SW3		
L	500	6	18	85	56	14	ESV-L-06	18,15
L	500	8	20	85	56	17	ESV-L-08	19,79
L	500	10	22	87	58	19	ESV-L-10	23,52
L	400	12	25	87	58	22	ESV-L-12	26,33
L	400	15	28	100	70	27	ESV-L-15	37,73
L	400	18	32	101	69	32	ESV-L-18	49,60
L	250	22	36	105	73	36	ESV-L-22	74,14
L	250	28	40	106	73	41	ESV-L-28	94,59
L	250	35	50	114	71	50	ESV-L-35	120,16
L	250	42	60	115	70	60	ESV-L-42	176,40

Reihe Series	Druck Pressure PN	Rohr A.D. Tube O.D.		Ca. Maße Approx. Dimensions			Bestellzeichen Order-Code Standard	Brutto-Preis Gross-Price Euro (€)
		D1	D2	L1	L2	SW3		
S	800	6	20	89	60	17	ESV-S-06	20,96
S	800	8	22	89	60	19	ESV-S-08	23,98
S	800	10	25	91	59	22	ESV-S-10	28,12
S	630	12	28	91	59	24	ESV-S-12	32,88
S	630	14	30	107	72	27	ESV-S-14	45,89
S	630	16	35	107	71	30	ESV-S-16	55,53
S	420	20	38	114	71	36	ESV-S-20	92,03
S	420	25	45	120	72	46	ESV-S-25	99,70
S	420	30	50	126	73	50	ESV-S-30	122,71
S	420	38	60	133	72	60	ESV-S-38	176,40



Einschweiß-Schottverschraubungen

Welding Bulkhead Connections

Reihe Series	Druck Pressure PN	Rohr A.D. Tube O.D.		Ca. Maße Approx. Dimensions			Bestellzeichen Order-Code SC	Brutto-Preis Gross-Price Euro (€)
		D1	D2	L1	L2	SW3		
L	500	6	18	85	56	14	ESV-L-06-SC	18,79
L	500	8	20	85	56	17	ESV-L-08-SC	20,67
L	500	10	22	87	58	19	ESV-L-10-SC	24,40
L	400	12	25	87	58	22	ESV-L-12-SC	27,45
L	400	15	28	100	70	27	ESV-L-15-SC	39,89
L	400	18	32	101	69	32	ESV-L-18-SC	52,88
L	250	22	36	105	73	36	ESV-L-22-SC	77,66
L	250	28	40	106	73	41	ESV-L-28-SC	98,59
L	250	35	50	114	71	50	ESV-L-35-SC	127,60
L	250	42	60	115	70	60	ESV-L-42-SC	185,04

Reihe Series	Druck Pressure PN	Rohr A.D. Tube O.D.		Ca. Maße Approx. Dimensions			Bestellzeichen Order-Code SC	Brutto-Preis Gross-Price Euro (€)
		D1	D2	L1	L2	SW3		
S	800	6	20	89	60	17	ESV-S-06-SC	21,84
S	800	8	22	89	60	19	ESV-S-08-SC	24,86
S	800	10	25	91	59	22	ESV-S-10-SC	29,24
S	630	12	28	91	59	24	ESV-S-12-SC	34,56
S	630	14	30	107	72	27	ESV-S-14-SC	49,01
S	630	16	35	107	71	30	ESV-S-16-SC	58,65
S	420	20	38	114	71	36	ESV-S-20-SC	95,79
S	420	25	45	120	72	46	ESV-S-25-SC	105,70
S	420	30	50	126	73	50	ESV-S-30-SC	131,03
S	420	38	60	133	72	60	ESV-S-38-SC	187,68

Einschweiß-Schottverschraubungsstutzen

Welding Bulkhead Connection Bodies



Reihe Series	Druck Pressure PN	Rohr A.D. Tube O.D.		Ca. Maße Approx. Dimensions			Bestellzeichen Order-Code OMD	Brutto-Preis Gross-Price Euro (€)
		D1	D2					
L	500	6	18				ESV-L-06-OMD	13,53
L	500	8	20				ESV-L-08-OMD	14,19
L	500	10	22				ESV-L-10-OMD	16,80
L	400	12	25				ESV-L-12-OMD	18,55
L	400	15	28				ESV-L-15-OMD	27,45
L	400	18	32				ESV-L-18-OMD	32,36
L	250	22	36				ESV-L-22-OMD	53,52
L	250	28	40				ESV-L-28-OMD	64,89
L	250	35	50				ESV-L-35-OMD	77,94
L	250	42	60				ESV-L-42-OMD	121,54

Reihe Series	Druck Pressure PN	Rohr A.D. Tube O.D.		Ca. Maße Approx. Dimensions			Bestellzeichen Order-Code OMD	Brutto-Preis Gross-Price Euro (€)
		D1	D2					
S	800	6	20				ESV-S-06-OMD	15,38
S	800	8	22				ESV-S-08-OMD	17,58
S	800	10	25				ESV-S-10-OMD	20,24
S	630	12	28				ESV-S-12-OMD	23,98
S	630	14	30				ESV-S-14-OMD	34,89
S	630	16	35				ESV-S-16-OMD	39,11
S	420	20	38				ESV-S-20-OMD	70,87
S	420	25	45				ESV-S-25-OMD	62,46
S	420	30	50				ESV-S-30-OMD	75,83
S	420	38	60				ESV-S-38-OMD	113,12

Gerade Anschweißverschraubungen

Straight Welding Bosses

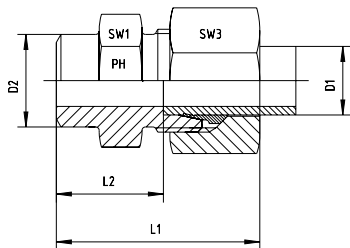

Reihe Series	Druck Pressure PN	Rohr A.D. Tube O.D.		Ca. Maße Approx. Dimensions				Bestellzeichen Order-Code Standard	Brutto-Preis Gross-Price Euro (€)
		D1	D2	L1	L2	SW1	SW3		
L	500	6	10	29	14,0	12	14	ASV-L-06	8,18
L	500	8	12	31	16,0	14	17	ASV-L-08	9,02
L	500	10	14	33	18,0	17	19	ASV-L-10	10,89
L	400	12	16	33	18,0	19	27	ASV-L-12	11,27
L	400	15	19	37	22,0	22	27	ASV-L-15	14,19
L	400	18	22	40	23,5	27	32	ASV-L-18	23,42
L	250	22	27	45	28,5	32	36	ASV-L-22	31,19
L	250	28	32	47	30,5	41	41	ASV-L-28	45,51
L	250	35	40	54	32,5	46	50	ASV-L-35	58,80
L	250	42	46	58	35,0	55	60	ASV-L-42	79,25

Reihe Series	Druck Pressure PN	Rohr A.D. Tube O.D.		Ca. Maße Approx. Dimensions				Bestellzeichen Order-Code Standard	Brutto-Preis Gross-Price Euro (€)
		D1	D2	L1	L2	SW1	SW3		
S	800	6	11	34	19,0	14	17	ASV-S-06	10,79
S	800	8	13	36	21,0	17	19	ASV-S-08	12,22
S	800	10	15	39	22,5	19	22	ASV-S-10	13,37
S	630	12	17	41	24,5	22	24	ASV-S-12	13,55
S	630	14	19	45	27,0	24	27	ASV-S-14	18,05
S	630	16	21	45	26,5	27	30	ASV-S-16	23,88
S	420	20	26	51	29,5	32	36	ASV-S-20	33,23
S	420	25	31	56	32,0	41	46	ASV-S-25	51,39
S	420	30	36	62	35,5	46	50	ASV-S-30	63,40
S	420	38	44	69	38,0	55	60	ASV-S-38	84,36

Gerade Anschweißverschraubungen

Straight Welding Bosses

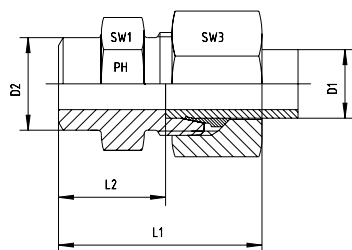

Reihe Series	Druck Pressure PN	Rohr A.D. Tube O.D.		Ca. Maße Approx. Dimensions				Bestellzeichen Order-Code SC	Brutto-Preis Gross-Price Euro (€)
		D1	D2	L1	L2	SW1	SW3		
L	500	6	10	29	14,0	12	14	ASV-L-06-SC	8,50
L	500	8	12	31	16,0	14	17	ASV-L-08-SC	9,46
L	500	10	14	33	18,0	17	19	ASV-L-10-SC	11,33
L	400	12	16	33	18,0	19	27	ASV-L-12-SC	11,83
L	400	15	19	37	22,0	22	27	ASV-L-15-SC	15,27
L	400	18	22	40	23,5	27	32	ASV-L-18-SC	25,06
L	250	22	27	45	28,5	32	36	ASV-L-22-SC	32,95
L	250	28	32	47	30,5	41	41	ASV-L-28-SC	47,51
L	250	35	40	54	32,5	46	50	ASV-L-35-SC	62,52
L	250	42	46	58	35,0	55	60	ASV-L-42-SC	83,57

Reihe Series	Druck Pressure PN	Rohr A.D. Tube O.D.		Ca. Maße Approx. Dimensions				Bestellzeichen Order-Code SC	Brutto-Preis Gross-Price Euro (€)
		D1	D2	L1	L2	SW1	SW3		
S	800	6	11	34	19,0	14	17	ASV-S-06-SC	11,23
S	800	8	13	36	21,0	17	19	ASV-S-08-SC	12,66
S	800	10	15	39	22,5	19	22	ASV-S-10-SC	13,93
S	630	12	17	41	24,5	22	24	ASV-S-12-SC	14,39
S	630	14	19	45	27,0	24	27	ASV-S-14-SC	19,61
S	630	16	21	45	26,5	27	30	ASV-S-16-SC	25,44
S	420	20	26	51	29,5	32	36	ASV-S-20-SC	35,11
S	420	25	31	56	32,0	41	46	ASV-S-25-SC	54,39
S	420	30	36	62	35,5	46	50	ASV-S-30-SC	67,56
S	420	38	44	69	38,0	55	60	ASV-S-38-SC	90,00

Gerade Anschweißverschraubungsstutzen

Straight Welding Boss Bodies



Reihe Series	Druck Pressure PN	Rohr A.D. Tube O.D.		Ca. Maße Approx. Dimensions				Bestellzeichen Order-Code OMD	Brutto-Preis Gross-Price Euro (€)
		D1	D2						
L	500	6	10					ASV-L-06-OMD	5,87
L	500	8	12					ASV-L-08-OMD	6,22
L	500	10	14					ASV-L-10-OMD	7,53
L	400	12	16					ASV-L-12-OMD	7,38
L	400	15	19					ASV-L-15-OMD	9,05
L	400	18	22					ASV-L-18-OMD	14,80
L	250	22	27					ASV-L-22-OMD	20,88
L	250	28	32					ASV-L-28-OMD	30,66
L	250	35	40					ASV-L-35-OMD	37,69
L	250	42	46					ASV-L-42-OMD	51,82

Reihe Series	Druck Pressure PN	Rohr A.D. Tube O.D.		Ca. Maße Approx. Dimensions				Bestellzeichen Order-Code OMD	Brutto-Preis Gross-Price Euro (€)
		D1	D2						
S	800	6	11					ASV-S-06-OMD	8,00
S	800	8	13					ASV-S-08-OMD	9,02
S	800	10	15					ASV-S-10-OMD	9,43
S	630	12	17					ASV-S-12-OMD	9,10
S	630	14	19					ASV-S-14-OMD	12,55
S	630	16	21					ASV-S-16-OMD	15,67
S	420	20	26					ASV-S-20-OMD	22,65
S	420	25	31					ASV-S-25-OMD	32,77
S	420	30	36					ASV-S-30-OMD	39,96
S	420	38	44					ASV-S-38-OMD	52,55



Winkel-Anschweißverschraubungen

Elbow Welding Couplings

Reihe Series	Druck Pressure PN	Rohr A.D. Tube O.D.		Ca. Maße Approx. Dimensions					Bestellzeichen Order-Code Standard	Brutto-Preis Gross-Price Euro (€)
		D1	D2	L1	L2	L3	SW2	SW3		
L	500	6	10	27	12,0	19	12	14	WAS-L-06	16,50
L	500	8	12	29	14,0	23	12	17	WAS-L-08	20,75
L	500	10	14	30	15,0	24	14	19	WAS-L-10	22,70
L	400	12	16	32	17,0	25	17	22	WAS-L-12	25,40
L	400	15	19	36	21,0	30	19	27	WAS-L-15	34,55
L	400	18	22	40	23,5	33	24	32	WAS-L-18	48,45
L	250	22	27	44	27,5	37	27	36	WAS-L-22	65,40
L	250	28	32	47	30,5	42	36	41	WAS-L-28	134,25
L	250	35	40	56	34,5	49	41	50	WAS-L-35	222,45
L	250	42	46	63	40,0	57	50	60	WAS-L-42	295,30

Reihe Series	Druck Pressure PN	Rohr A.D. Tube O.D.		Ca. Maße Approx. Dimensions					Bestellzeichen Order-Code Standard	Brutto-Preis Gross-Price Euro (€)
		D1	D2	L1	L2	L3	SW2	SW3		
S	800	6	11	31	16,0	23	12	17	WAS-S-06	*
S	800	8	13	32	17,0	24	14	19	WAS-S-08	28,00
S	800	10	15	34	17,5	25	17	22	WAS-S-10	28,90
S	630	12	17	38	21,5	29	17	24	WAS-S-12	34,75
S	630	14	19	40	22,0	30	19	27	WAS-S-14	*
S	630	16	21	43	24,5	33	24	30	WAS-S-16	61,10
S	420	20	26	48	26,5	37	27	36	WAS-S-20	68,55
S	420	25	31	54	30,0	42	36	46	WAS-S-25	149,55
S	420	30	36	62	35,5	49	41	50	WAS-S-30	222,45
S	420	38	44	72	41,0	57	50	60	WAS-S-38	306,80



Winkel-Anschweißverschraubungen

Elbow Welding Couplings

Reihe Series	Druck Pressure PN	Rohr A.D. Tube O.D.		Ca. Maße Approx. Dimensions					Bestellzeichen Order-Code SC	Brutto-Preis Gross-Price Euro (€)
		D1	D2	L1	L2	L3	SW2	SW3		
L	500	6	10	27	12,0	19	12	14	WAS-L-06-SC	16,82
L	500	8	12	29	14,0	23	12	17	WAS-L-08-SC	21,19
L	500	10	14	30	15,0	24	14	19	WAS-L-10-SC	23,14
L	400	12	16	32	17,0	25	17	22	WAS-L-12-SC	25,96
L	400	15	19	36	21,0	30	19	27	WAS-L-15-SC	35,63
L	400	18	22	40	23,5	33	24	32	WAS-L-18-SC	50,09
L	250	22	27	44	27,5	37	27	36	WAS-L-22-SC	67,16
L	250	28	32	47	30,5	42	36	41	WAS-L-28-SC	136,25
L	250	35	40	56	34,5	49	41	50	WAS-L-35-SC	226,17
L	250	42	46	63	40,0	57	50	60	WAS-L-42-SC	299,62

Reihe Series	Druck Pressure PN	Rohr A.D. Tube O.D.		Ca. Maße Approx. Dimensions					Bestellzeichen Order-Code SC	Brutto-Preis Gross-Price Euro (€)
		D1	D2	L1	L2	L3	SW2	SW3		
S	800	6	11	31	16,0	23	12	17	WAS-S-06-SC	*
S	800	8	13	32	17,0	24	14	19	WAS-S-08-SC	*
S	800	10	15	34	17,5	25	17	22	WAS-S-10-SC	29,46
S	630	12	17	38	21,5	29	17	24	WAS-S-12-SC	35,59
S	630	14	19	40	22,0	30	19	27	WAS-S-14-SC	*
S	630	16	21	43	24,5	33	24	30	WAS-S-16-SC	62,66
S	420	20	26	48	26,5	37	27	36	WAS-S-20-SC	70,43
S	420	25	31	54	30,0	42	36	46	WAS-S-25-SC	152,55
S	420	30	36	62	35,5	49	41	50	WAS-S-30-SC	226,61
S	420	38	44	72	41,0	57	50	60	WAS-S-38-SC	312,44

Winkel-Anschweißverschraubungsstutzen

Elbow Welding Coupling Bodies



Reihe Series	Druck Pressure PN	Rohr A.D. Tube O.D.		Ca. Maße Approx. Dimensions				Bestellzeichen Order-Code OMD	Brutto-Preis Gross-Price Euro (€)
		D1	D2						
L	500	6	10					WAS-L-06-OMD	14,19
L	500	8	12					WAS-L-08-OMD	17,95
L	500	10	14					WAS-L-10-OMD	19,34
L	400	12	16					WAS-L-12-OMD	21,51
L	400	15	19					WAS-L-15-OMD	29,41
L	400	18	22					WAS-L-18-OMD	39,83
L	250	22	27					WAS-L-22-OMD	55,09
L	250	28	32					WAS-L-28-OMD	119,40
L	250	35	40					WAS-L-35-OMD	201,34
L	250	42	46					WAS-L-42-OMD	267,87

Reihe Series	Druck Pressure PN	Rohr A.D. Tube O.D.		Ca. Maße Approx. Dimensions				Bestellzeichen Order-Code OMD	Brutto-Preis Gross-Price Euro (€)
		D1	D2						
S	800	6	11					WAS-S-06-OMD	*
S	800	8	13					WAS-S-08-OMD	24,80
S	800	10	15					WAS-S-10-OMD	24,96
S	630	12	17					WAS-S-12-OMD	30,30
S	630	14	19					WAS-S-14-OMD	*
S	630	16	21					WAS-S-16-OMD	52,89
S	420	20	26					WAS-S-20-OMD	57,97
S	420	25	31					WAS-S-25-OMD	130,93
S	420	30	36					WAS-S-30-OMD	199,01
S	420	38	44					WAS-S-38-OMD	274,99

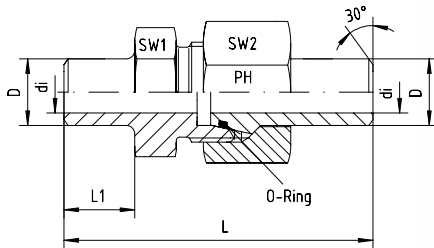

Schweißkegel-Verschraubungen
Mit O-Ring Abdichtung - NBR
Auf Anfrage: Viton

Welding Nipple Couplings
With O-ring Sealing - NBR
On request: Viton

Reihe Series	Druck Pressure PN	Rohr A. D. Tube O. D.	Ca. Maße Approx. Dimensions						O-Ring O-ring	Bestellzeichen Order-Code Standard	Brutto-Preis Gross-Price Euro (€)
			L	L1	D	di	SW1	SW3			
S	528	6 x 1,5	52,5	10,0	6	3	14	17	4,0 x 1,5	ASV-K-6x1,5	16,31
S	414	8 x 1,5	52,5	10,0	8	5	17	19	6,0 x 1,5	ASV-K-8x1,5	18,25
S	528	8 x 2	52,5	10,0	8	4	17	19	6,0 x 1,5	ASV-K-8x2	18,25
S	249	10 x 1	58,0	10,0	10	8	19	22	8,0 x 1,5	ASV-K-10x1	19,61
S	358	10 x 1,5	58,0	10,0	10	7	19	22	8,0 x 1,5	ASV-K-10x1,5	19,61
S	460	10 x 2	58,0	10,0	10	6	19	22	8,0 x 1,5	ASV-K-10x2	19,61
S	305	12 x 1,5	63,0	15,0	12	9	22	24	10,0 x 1,5	ASV-K-12x1,5	20,22
S	393	12 x 2	63,0	15,0	12	8	22	24	10,0 x 1,5	ASV-K-12x2	20,22
S	476	12 x 2,5	63,0	15,0	12	7	22	24	10,0 x 1,5	ASV-K-12x2,5	20,22
S	343	14 x 2	73,0	15,0	14	10	24	27	10,0 x 2,0	ASV-K-14x2	27,61
S	487	14 x 3	73,0	15,0	14	8	24	27	10,0 x 2,0	ASV-K-14x3	27,61
S	305	16 x 2	73,5	16,5	16	12	27	30	13,0 x 2,0	ASV-K-16x2	32,72
S	372	16 x 2,5	73,5	16,5	16	11	27	30	13,0 x 2,0	ASV-K-16x2,5	32,72
S	400	16 x 3	73,5	16,5	16	10	27	30	13,0 x 2,0	ASV-K-16x3	32,72
S	249	20 x 2	83,5	19,0	20	16	32	36	16,0 x 2,0	ASV-K-20x2	44,99
S	305	20 x 2,5	83,5	19,0	20	15	32	36	16,3 x 2,4	ASV-K-20x2,5	44,99
S	358	20 x 3	83,5	19,0	20	14	32	36	16,3 x 2,4	ASV-K-20x3	44,99
S	400	20 x 4	83,5	19,0	20	12	32	36	16,3 x 2,4	ASV-K-20x4	44,99
S	294	25 x 3	92,5	19,5	25	19	41	46	21,3 x 2,4	ASV-K-25x3	72,14
S	379	25 x 4	92,5	19,5	25	17	41	46	21,3 x 2,4	ASV-K-25x4	72,14
S	400	25 x 5	92,5	19,5	25	15	41	46	21,3 x 2,4	ASV-K-25x5	72,14
S	249	30 x 3	101,5	23,0	30	24	46	50	25,3 x 2,4	ASV-K-30x3	89,99
S	323	30 x 4	101,5	23,0	30	22	46	50	25,3 x 2,4	ASV-K-30x4	89,99
S	393	30 x 5	101,5	23,0	30	20	46	50	25,3 x 2,4	ASV-K-30x5	89,99
S	400	30 x 6	101,5	23,0	30	18	46	50	25,3 x 2,4	ASV-K-30x6	89,99
S	261	38 x 4	108,0	22,0	38	30	55	60	34,0 x 2,5	ASV-K-38x4	102,26
S	315	38 x 5	108,0	22,0	38	28	55	60	34,0 x 2,5	ASV-K-38x5	102,26
S	315	38 x 6	108,0	22,0	38	26	55	60	34,0 x 2,5	ASV-K-38x6	102,26
S	315	38 x 7	108,0	22,0	38	24	55	60	34,0 x 2,5	ASV-K-38x7	102,26
S	250	50 x 5	118,0	23,0	50	40	70	80	46,0 x 3,0	ASV-K-50x5	417,00
S	310	50 x 6	118,0	23,0	50	38	70	80	46,0 x 3,0	ASV-K-50x6	417,00
S	350	50 x 7	118,0	23,0	50	36	70	80	46,0 x 3,0	ASV-K-50x7	417,00

Reihe Series	Druck Pressure PN	Rohr A. D. Tube O. D.	Ca. Maße Approx. Dimensions						O-Ring O-ring	Bestellzeichen Order-Code Standard	Brutto-Preis Gross-Price Euro (€)
			L	L1	D	di	SW1	SW3			
L	323	15 x 2	54,5	15,0	15	11	22	27	12,0 x 2,0	ASV-K-15x2	31,72
L	315	18 x 2	57,5	16,0	18	14	27	32	15,0 x 2,0	ASV-K-18x2	34,22
L	280	22 x 2,5	74,0	19,0	22	17	32	36	19,0 x 2,0	ASV-K-22x2,5	47,99
L	265	28 x 3	78,0	19,0	28	22	41	41	25,0 x 2,0	ASV-K-28x3	73,14
L	231	35 x 3	87,5	22,0	35	29	46	50	32,0 x 2,5	ASV-K-35x3	90,49
L	182	42 x 3	87,0	22,0	42	36	55	60	38,0 x 2,5	ASV-K-42x3	102,26

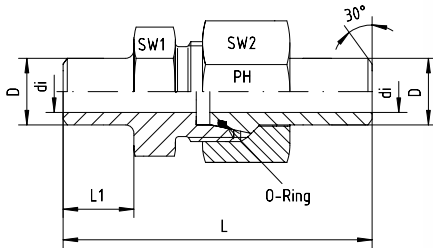

Schweißkegel-Verschraubungen
Mit O-Ring Abdichtung - NBR
Auf Anfrage: Viton

Welding Nipple Couplings
With O-ring Sealing - NBR
On request: Viton

Reihe Series	Druck Pressure PN	Rohr A. D. Tube O. D.	Ca. Maße Approx. Dimensions						O-Ring O-ring	Bestellzeichen Order-Code SC	Brutto-Preis Gross-Price Euro (€)
			L	L1	D	di	SW1	SW3			
S	528	6 x 1,5			6	3	14	17	4,0 x 1,5	ASV-K-6x1,5-SC	16,75
S	414	8 x 1,5			8	5	17	19	6,0 x 1,5	ASV-K-8x1,5-SC	18,69
S	528	8 x 2			8	4	17	19	6,0 x 1,5	ASV-K-8x2-SC	18,69
S	249	10 x 1	58,0	10,0	10	8	19	22	8,0 x 1,5	ASV-K-10x1-SC	20,17
S	358	10 x 1,5	58,0	10,0	10	7	19	22	8,0 x 1,5	ASV-K-10x1,5-SC	20,17
S	460	10 x 2	58,0	10,0	10	6	19	22	8,0 x 1,5	ASV-K-10x2-SC	20,17
S	305	12 x 1,5	63,0	15,0	12	9	22	24	10,0 x 1,5	ASV-K-12x1,5-SC	21,06
S	393	12 x 2	63,0	15,0	12	8	22	24	10,0 x 1,5	ASV-K-12x2-SC	21,06
S	476	12 x 2,5	63,0	15,0	12	7	22	24	10,0 x 1,5	ASV-K-12x2,5-SC	21,06
S	343	14 x 2			14	10	24	27	10,0 x 2,0	ASV-K-14x2-SC	29,17
S	487	14 x 3			14	8	24	27	10,0 x 2,0	ASV-K-14x3-SC	29,17
S	305	16 x 2	73,5	16,5	16	12	27	30	13,0 x 2,0	ASV-K-16x2-SC	34,28
S	372	16 x 2,5	73,5	16,5	16	11	27	30	13,0 x 2,0	ASV-K-16x2,5-SC	34,28
S	400	16 x 3	73,5	16,5	16	10	27	30	13,0 x 2,0	ASV-K-16x3-SC	34,28
S	249	20 x 2	83,5	19,0	20	16	32	36	16,0 x 2,0	ASV-K-20x2-SC	46,87
S	305	20 x 2,5	83,5	19,0	20	15	32	36	16,3 x 2,4	ASV-K-20x2,5-SC	46,87
S	358	20 x 3	83,5	19,0	20	14	32	36	16,3 x 2,4	ASV-K-20x3-SC	46,87
S	400	20 x 4	83,5	19,0	20	12	32	36	16,3 x 2,4	ASV-K-20x4-SC	46,87
S	294	25 x 3	92,5	19,5	25	19	41	46	21,3 x 2,4	ASV-K-25x3-SC	75,14
S	379	25 x 4	92,5	19,5	25	17	41	46	21,3 x 2,4	ASV-K-25x4-SC	75,14
S	400	25 x 5	92,5	19,5	25	15	41	46	21,3 x 2,4	ASV-K-25x5-SC	75,14
S	249	30 x 3	101,5	23,0	30	24	46	50	25,3 x 2,4	ASV-K-30x3-SC	94,15
S	323	30 x 4	101,5	23,0	30	22	46	50	25,3 x 2,4	ASV-K-30x4-SC	94,15
S	393	30 x 5	101,5	23,0	30	20	46	50	25,3 x 2,4	ASV-K-30x5-SC	94,15
S	400	30 x 6	101,5	23,0	30	18	46	50	25,3 x 2,4	ASV-K-30x6-SC	94,15
S	261	38 x 4	108,0	22,0	38	30	55	60	34,0 x 2,5	ASV-K-38x4-SC	107,90
S	315	38 x 5	108,0	22,0	38	28	55	60	34,0 x 2,5	ASV-K-38x5-SC	107,90
S	315	38 x 6	108,0	22,0	38	26	55	60	34,0 x 2,5	ASV-K-38x6-SC	107,90
S	315	38 x 7	108,0	22,0	38	24	55	60	34,0 x 2,5	ASV-K-38x7-SC	107,90
S	250	50 x 5	118,0	23,0	50	40	70	80	46,0 x 3,0	ASV-K-50x5-SC	*
S	310	50 x 6	118,0	23,0	50	38	70	80	46,0 x 3,0	ASV-K-50x6-SC	*
S	350	50 x 7	118,0	23,0	50	36	70	80	46,0 x 3,0	ASV-K-50x7-SC	*

Reihe Series	Druck Pressure PN	Rohr A. D. Tube O. D.	Ca. Maße Approx. Dimensions						O-Ring O-ring	Bestellzeichen Order-Code SC	Brutto-Preis Gross-Price Euro (€)
			L	L1	D	di	SW1	SW3			
L	323	15 x 2	54,5	15,0	15	11	22	27	12,0 x 2,0	ASV-K-15x2-SC	33,28
L	315	18 x 2	57,5	16,0	18	14	27	32	15,0 x 2,0	ASV-K-18x2-SC	35,78
L	280	22 x 2,5	74,0	19,0	22	17	32	36	19,0 x 2,0	ASV-K-22x2,5-SC	49,87
L	265	28 x 3	78,0	19,0	28	22	41	41	25,0 x 2,0	ASV-K-28x3-SC	76,14
L	231	35 x 3	87,5	22,0	35	29	46	50	32,0 x 2,5	ASV-K-35x3-SC	94,65
L	182	42 x 3	87,0	22,0	42	36	55	60	38,0 x 2,5	ASV-K-42x3-SC	107,90



Schweißkegel-Verschraubungsstutzen
Mit O-Ring Abdichtung - NBR
Auf Anfrage: Viton

*Welding Nipple Coupling Bodies
With O-ring Sealing - NBR
On request: Viton*

Reihe Series	Druck Pressure PN	Rohr A. D. Tube O. D.	Ca. Maße Approx. Dimensions				O-Ring O-ring	Bestellzeichen Order-Code OMD	Brutto-Preis Gross-Price Euro (€)
S	528	6 x 1,5					4,0 x 1,5	ASV-K-6x1,5-OMD	8,74
S	414	8 x 1,5					6,0 x 1,5	ASV-K-8x1,5-OMD	9,02
S	528	8 x 2					6,0 x 1,5	ASV-K-8x2-OMD	9,02
S	249	10 x 1					8,0 x 1,5	ASV-K-10x1-OMD	9,43
S	358	10 x 1,5					8,0 x 1,5	ASV-K-10x1,5-OMD	9,43
S	460	10 x 2					8,0 x 1,5	ASV-K-10x2-OMD	9,43
S	305	12 x 1,5					10,0 x 1,5	ASV-K-12x1,5-OMD	8,92
S	393	12 x 2					10,0 x 1,5	ASV-K-12x2-OMD	8,92
S	476	12 x 2,5					10,0 x 1,5	ASV-K-12x2,5-OMD	8,92
S	343	14 x 2					10,0 x 2,0	ASV-K-14x2-OMD	14,21
S	487	14 x 3					10,0 x 2,0	ASV-K-14x3-OMD	14,21
S	305	16 x 2					13,0 x 2,0	ASV-K-16x2-OMD	14,90
S	372	16 x 2,5					13,0 x 2,0	ASV-K-16x2,5-OMD	14,90
S	400	16 x 3					13,0 x 2,0	ASV-K-16x3-OMD	14,90
S	249	20 x 2					16,0 x 2,0	ASV-K-20x2-OMD	22,16
S	305	20 x 2,5					16,3 x 2,4	ASV-K-20x2,5-OMD	22,16
S	358	20 x 3					16,3 x 2,4	ASV-K-20x3-OMD	22,16
S	400	20 x 4					16,3 x 2,4	ASV-K-20x4-OMD	22,16
S	294	25 x 3					21,3 x 2,4	ASV-K-25x3-OMD	35,73
S	379	25 x 4					21,3 x 2,4	ASV-K-25x4-OMD	35,73
S	400	25 x 5					21,3 x 2,4	ASV-K-25x5-OMD	35,73
S	249	30 x 3					25,3 x 2,4	ASV-K-30x3-OMD	44,51
S	323	30 x 4					25,3 x 2,4	ASV-K-30x4-OMD	44,51
S	393	30 x 5					25,3 x 2,4	ASV-K-30x5-OMD	44,51
S	400	30 x 6					25,3 x 2,4	ASV-K-30x6-OMD	44,51
S	261	38 x 4					34,0 x 2,5	ASV-K-38x4-OMD	39,37
S	315	38 x 5					34,0 x 2,5	ASV-K-38x5-OMD	39,37
S	315	38 x 6					34,0 x 2,5	ASV-K-38x6-OMD	39,37
S	315	38 x 7					34,0 x 2,5	ASV-K-38x7-OMD	39,37
S	250	50 x 5					46,0 x 3,0	ASV-K-50x5-OMD	229,00
S	310	50 x 6					46,0 x 3,0	ASV-K-50x6-OMD	229,00
S	350	50 x 7					46,0 x 3,0	ASV-K-50x7-OMD	229,00

Reihe Series	Druck Pressure PN	Rohr A. D. Tube O. D.	Ca. Maße Approx. Dimensions				O-Ring O-ring	Bestellzeichen Order-Code OMD	Brutto-Preis Gross-Price Euro (€)
L	323	15 x 2					12,0 x 2,0	ASV-K-15x2-OMD	13,90
L	315	18 x 2					15,0 x 2,0	ASV-K-18x2-OMD	16,40
L	280	22 x 2,5					19,0 x 2,0	ASV-K-22x2,5-OMD	25,16
L	265	28 x 3					25,0 x 2,0	ASV-K-28x3-OMD	36,73
L	231	35 x 3					32,0 x 2,5	ASV-K-35x3-OMD	45,01
L	182	42 x 3					38,0 x 2,5	ASV-K-42x3-OMD	39,37

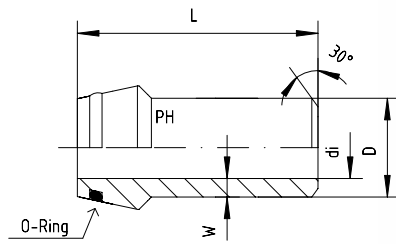

Mit O-Ring Abdichtung - NBR
Auf Anfrage: Viton
Passend in 24°-Innenkonus
Bohrungsform W DIN 3861

With O-ring Sealing - NBR
On request: Viton
Matching Type 24°-Inside Tapers
Bore Type W DIN 3861

Reihe Series	Druck Pressure PN	D x W	Ca. Maße Approx. Dimensions		O-Ring O-ring	Bestellzeichen Order-Code	Brutto-Preis Gross-Price Euro (€)
			di	L			
L + S	528	6 x 1,5	3	31,0	4,0 x 1,5	SKV-6x1,5	5,37
L + S	414	8 x 1,5	5	31,0	6,0 x 1,5	SKV-8x1,5	6,72
L + S	528	8 x 2	4	31,0	6,0 x 1,5	SKV-8x2	6,72
L + S	249	10 x 1	8	32,5	8,0 x 1,5	SKV-10x1	7,21
L + S	358	10 x 1,5	7	32,5	8,0 x 1,5	SKV-10x1,5	7,21
L + S	460	10 x 2	6	32,5	8,0 x 1,5	SKV-10x2	7,21
L + S	305	12 x 1,5	9	32,5	10,0 x 1,5	SKV-12x1,5	7,95
L + S	393	12 x 2	8	32,5	10,0 x 1,5	SKV-12x2	7,95
L + S	476	12 x 2,5	7	32,5	10,0 x 1,5	SKV-12x2,5	7,95
L + S	476	12 x 3	6	32,5	10,0 x 1,5	SKV-12x3	7,95
S	343	14 x 2	10	40,0	10,0 x 2,0	SKV-14x2	9,23
S	415	14 x 2,5	9	40,0	10,0 x 2,0	SKV-14x2,5	9,23
S	487	14 x 3	8	40,0	10,0 x 2,0	SKV-14x3	9,23
L	270	15 x 1,5	12	36,0	12,0 x 2,0	SKV-15x1,5	10,33
L	323	15 x 2	11	36,0	12,0 x 2,0	SKV-15x2	10,33
L	393	15 x 2,5	10	36,0	12,0 x 2,0	SKV-15x2,5	10,33
S	305	16 x 2	12	38,5	13,0 x 2,0	SKV-16x2	10,99
S	372	16 x 2,5	11	38,5	13,0 x 2,0	SKV-16x2,5	10,99
S	435	16 x 3	10	38,5	13,0 x 2,0	SKV-16x3	10,99
L	225	18 x 1,5	15	37,0	16,0 x 1,5	SKV-18x1,5	12,71
L	300	18 x 2	14	37,0	15,0 x 2,0	SKV-18x2	12,71
L	335	18 x 2,5	13	37,0	15,0 x 2,0	SKV-18x2,5	12,71
S	249	20 x 2	16	44,5	16,0 x 2,0	SKV-20x2	13,86
S	305	20 x 2,5	15	44,5	16,3 x 2,4	SKV-20x2,5	13,86
S	358	20 x 3	14	44,5	16,3 x 2,4	SKV-20x3	13,86
S	460	20 x 4	12	44,5	16,3 x 2,4	SKV-20x4	13,86
L	245	22 x 2	18	38,5	19,0 x 2,0	SKV-22x2	15,47
L	280	22 x 2,5	17	38,5	19,0 x 2,0	SKV-22x2,5	15,47
L	328	22 x 3	16	38,5	19,0 x 2,0	SKV-22x3	15,47
S	294	25 x 3	19	49,5	21,3 x 2,4	SKV-25x3	20,30
S	337	25 x 3,5	18	49,5	21,3 x 2,4	SKV-25x3,5	20,30
S	379	25 x 4	17	49,5	21,3 x 2,4	SKV-25x4	20,30
S	460	25 x 5	15	49,5	21,3 x 2,4	SKV-25x5	20,30
L	193	28 x 2	24	41,5	25,0 x 2,0	SKV-28x2	23,57
L	224	28 x 2,5	23	41,5	25,0 x 2,0	SKV-28x2,5	23,57
L	265	28 x 3	22	41,5	25,0 x 2,0	SKV-28x3	23,57
S	249	30 x 3	27	52,0	25,3 x 2,4	SKV-30x3	25,67
S	323	30 x 4	22	52,0	25,3 x 2,4	SKV-30x4	25,67
S	393	30 x 5	20	52,0	25,3 x 2,4	SKV-30x5	25,67
S	460	30 x 6	18	52,0	25,3 x 2,4	SKV-30x6	25,67
L	154	35 x 2	31	47,0	32,0 x 2,5	SKV-35x2	27,76
L	193	35 x 2,5	30	47,0	32,0 x 2,5	SKV-35x2,5	27,76
L	231	35 x 3	29	47,0	32,0 x 2,5	SKV-35x3	27,76
L	249	35 x 3,5	28	47,0	32,0 x 2,5	SKV-35x3,5	27,76
S	261	38 x 4	30	56,5	34,0 x 2,5	SKV-38x4	34,97
S	319	38 x 5	28	56,5	34,0 x 2,5	SKV-38x5	34,97
S	375	38 x 6	26	56,5	34,0 x 2,5	SKV-38x6	34,97
S	429	38 x 7	24	56,5	39,0 x 1,5	SKV-38x7	34,97
L	129	42 x 2	38	47,0	39,0 x 1,5	SKV-42x2	37,22
L	150	42 x 2,5	37	47,0	38,0 x 2,5	SKV-42x2,5	37,22
L	182	42 x 3	36	47,0	38,0 x 2,5	SKV-42x3	37,22
L	238	42 x 4	34	47,0	38,0 x 2,5	SKV-42x4	*
S	250	50 x 5	40	61,0	46,0 x 3,0	SKV-50x5	89,00
S	310	50 x 6	38	61,0	46,0 x 3,0	SKV-50x6	*
S	350	50 x 7	36	61,0	46,0 x 3,0	SKV-50x7	89,00

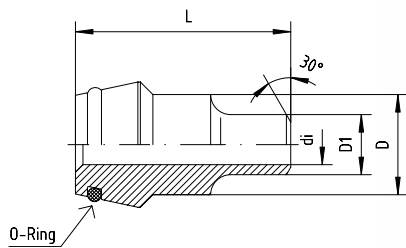

Mit O-Ring Abdichtung - NBR
 Auf Anfrage: Viton
 Passend in 24°-Innenkonus
 Bohrungsform W DIN 3861

With O-ring Sealing - NBR
 On request: Viton
 Matching Type 24°-Inside Tapers
 Bore Type W DIN 3861

Reihe Series	Druck Pressure PN	Ca. Maße Approx. Dimensions				O-Ring O-ring	Bestellzeichen Order-Code	Brutto-Preis Gross-Price Euro (€)
		D	D1	di	L			
S	380	8	6	4	30	6,0 x 1,5	SKV-R-8/6x1	*
S	528	8	6	3	30	6,0 x 1,5	SKV-R-8/6x1,5	10,05
S	414	10	8	5	32	8,0 x 1,5	SKV-R-10/8x1,5	10,05
S	528	10	8	4	32	8,0 x 1,5	SKV-R-10/8x2	10,05
S	528	10	6	3	32	8,0 x 1,5	SKV-R-10/6x1,5	10,05
S	358	12	10	7	32	10,0 x 1,5	SKV-R-12/10x1,5	10,55
S	460	12	10	6	32	10,0 x 1,5	SKV-R-12/10x2	10,55
S	414	12	8	5	32	10,0 x 1,5	SKV-R-12/8x1,5	10,55
S	380	12	6	4	32	10,0 x 1,5	SKV-R-12/6x1	*
S	528	12	6	3	32	10,0 x 1,5	SKV-R-12/6x1,5	*
S	393	16	12	8	39	13,0 x 2,0	SKV-R-16/12x2	12,40
S	460	16	10	6	39	13,0 x 2,0	SKV-R-16/10x2	12,40
S	414	16	8	5	39	13,0 x 2,0	SKV-R-16/8x1,5	12,40
S	435	20	16	10	43	16,3 x 2,4	SKV-R-20/16x3	15,20
S	372	20	16	11	43	16,3 x 2,4	SKV-R-20/16x2,5	15,20
S	305	20	16	12	43	16,3 x 2,4	SKV-R-20/16x2	15,20
S	393	20	12	8	43	16,3 x 2,4	SKV-R-20/12x2	15,20
S	358	20	10	7	43	16,3 x 2,4	SKV-R-20/10x1,5	15,20
S	414	20	8	5	43	16,3 x 2,4	SKV-R-20/8x1,5	16,50
S	358	25	20	14	50	21,3 x 2,4	SKV-R-25/20x3	21,60
S	305	25	20	15	50	21,3 x 2,4	SKV-R-25/20x2,5	21,60
S	249	25	20	16	50	21,3 x 2,4	SKV-R-25/20x2	21,60
S	435	25	16	10	50	21,3 x 2,4	SKV-R-25/16x3	21,60
S	372	25	16	11	50	21,3 x 2,4	SKV-R-25/16x2,5	21,60
S	305	25	16	12	50	21,3 x 2,4	SKV-R-25/16x2	21,60
S	393	25	12	8	50	21,3 x 2,4	SKV-R-25/12x2	21,60
S	460	25	10	6	50	21,3 x 2,4	SKV-R-25/10x2	23,90
S	294	30	25	19	52	25,3 x 2,4	SKV-R-30/25x3	38,00
S	358	30	20	14	52	25,3 x 2,4	SKV-R-30/20x3	38,00
S	435	30	16	10	52	25,3 x 2,4	SKV-R-30/16x3	38,00
S	393	30	12	8	52	25,3 x 2,4	SKV-R-30/12x2	39,90
S	323	38	30	22	58	34,0 x 2,5	SKV-R-38/30x4	49,60
S	249	38	30	24	58	34,0 x 2,5	SKV-R-38/30x3	49,60
S	379	38	25	17	58	34,0 x 2,5	SKV-R-38/25x4	49,60
S	294	38	25	19	58	34,0 x 2,5	SKV-R-38/25x3	49,60
S	358	38	20	14	58	34,0 x 2,5	SKV-R-38/20x3	49,60
S	305	38	20	15	58	34,0 x 2,5	SKV-R-38/20x2,5	49,60
S	435	38	16	10	58	34,0 x 2,5	SKV-R-38/16x3	49,60
S	305	38	16	12	58	34,0 x 2,5	SKV-R-38/16x2	49,60
S	393	38	12	8	58	34,0 x 2,5	SKV-R-38/12x2	56,80

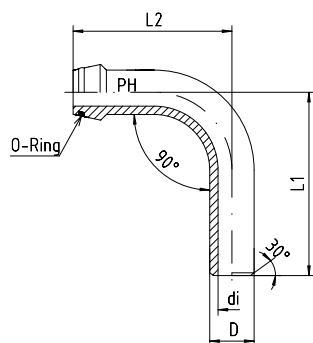

Mit O-Ring Abdichtung - NBR
Auf Anfrage: Viton
Passend in 24°-Innenkonus
Bohrungsform W DIN 3861

With O-ring Sealing - NBR
On request: Viton
Matching Type 24°-Inside Tapers
Bore Type W DIN 3861

Reihe Series	Druck Pressure PN	Rohr Tube	Ca. Maße Approx. Dimensions				O-Ring O-ring	Bestellzeichen Order-Code	Brutto-Preis Gross-Price Euro (€)
			D	di	L1	L2			
S	460	10 x 2	10	6	49	51	8,0 x 1,5	SKV-RB-10x2	37,85
S	393	12 x 2	12	8	50	51	10,0 x 1,5	SKV-RB-12x2	42,55
S	476	12 x 2,5	12	7	50	51	10,0 x 1,5	SKV-RB-12x2,5	42,55
S	305	16 x 2	16	12	72	67	13,0 x 2,0	SKV-RB-16x2	50,75
S	372	16 x 2,5	16	11	72	67	13,0 x 2,0	SKV-RB-16x2,5	50,75
S	435	16 x 3	16	10	72	67	13,0 x 2,0	SKV-RB-16x3	50,75
S	249	20 x 2	20	16	89	86	16,3 x 2,4	SKV-RB-20x2	60,20
S	305	20 x 2,5	20	15	89	86	16,3 x 2,4	SKV-RB-20x2,5	60,20
S	358	20 x 3	20	14	89	86	16,3 x 2,4	SKV-RB-20x3	60,20
L	328	22 x 3	22	16	79	85	19,0 x 2,0	SKV-RB-22x3	70,55
S	294	25 x 3	25	19	93	89	21,3 x 2,4	SKV-RB-25x3	70,55
S	379	25 x 4	25	17	93	89	21,3 x 2,4	SKV-RB-25x4	70,55
S	460	25 x 5	25	15	93	89	21,3 x 2,4	SKV-RB-25x5	70,55
S	323	30 x 4	30	22	112	105	25,3 x 2,4	SKV-RB-30x4	102,90
S	393	30 x 5	30	20	112	105	25,3 x 2,4	SKV-RB-30x5	102,90
S	460	30 x 6	30	18	112	105	25,3 x 2,4	SKV-RB-30x6	102,90
S	261	38 x 4	38	30	145	137	34,0 x 2,5	SKV-RB-38x4	130,60
S	319	38 x 5	38	28	145	137	34,0 x 2,5	SKV-RB-38x5	130,60
S	375	38 x 6	38	26	145	137	34,0 x 2,5	SKV-RB-38x6	130,60
S	429	38 x 7	38	24	145	137	34,0 x 2,5	SKV-RB-38x7	*

